



VER 1.0

Technical Manual

DS-OLBS6-FSC



Table of Contents

[C](#) Click to return to table of contents

- 1. Specification and Description.....3
- 2. Product Characteristic.....3
- 3. Terminal Connection.....4
 - 3.1 Power Input.....4
 - 3.2 Motor Input.....4
- 4. Connection Diagram of Motor and Driver.....4
- 5. Dimension.....5
- 6. Functions and Usage.....5
 - 6.1 Speed Adjustment Method.....5
 - 6.2 Motor Operate / Stop Control (EN).....6
 - 6.3 Motor Rotation Direction Control (F/R).....6
 - 6.4 Brake the Motor to Stop (BK).....6
 - 6.5 Speed Signal Output (PG).....6
 - 6.6 Alarm Output (ALM).....6
 - 6.7 Drive Failure.....7
- 7. Using.....7

Summary

This closed-loop speed controller is designed with the latest type IGBT and MOS power devices. It takes advantage of DC brushless motor's Hall signal to double frequency for closed-loop speed control. PID control links with the speed controller. The control system is stable and reliable, especially at low speed, it always can reach the maximum torque, The speed control range is from 150 to 10000rpm.

1. Specification and Description

- PID speed and current double loop regulator
- High performance, low price
- 20KHZ Chopper frequency
- Electrical stop to ensure the quickly action of motor
- Over load ratio larger then 2, torque always can achieve the max in low speed
- Provide OVP, LVP, OCP, OTP, illegal horal signal and other fault alarm.

2. Product Characteristic

Drive model	DS-OLBS6-FSC
Input voltage	24 VDC – 48 VDC
Min. Input voltage	12 VDC
Max input voltage	60 VDC
Maximum continuous output current	15 A
Accelerate time constant, default	2sec others can be customized



Warning

- * Do not measuring or touch any components without housing while operating.
- * Should check soleplate or change fuse 1minter later after power off.
- * Operating without housing is forbidden.
- * Make sure to connect the ground terminal, otherwise the brushless motor will working unsteadily
- * Sudden damage while drives working, our company only affords the service and replace in guarantee. Personal injury and motor damage caused by the accident will invalidate the guarantee.

3. Terminal Connection



3.1 Power Input

1	V+	24VDC - 48VDC input
2	GND	GND

3.2 Motor Input

1	MA	A phase
2	MB	B phase
3	MC	C phase
4	GND	Hall signal power negative
5	HA	Hall signal A input
6	HB	Hall signal B input
7	HC	Hall signal C input
8	+5V	Hall signal power positive

4. Connection Diagram of Motor and Driver

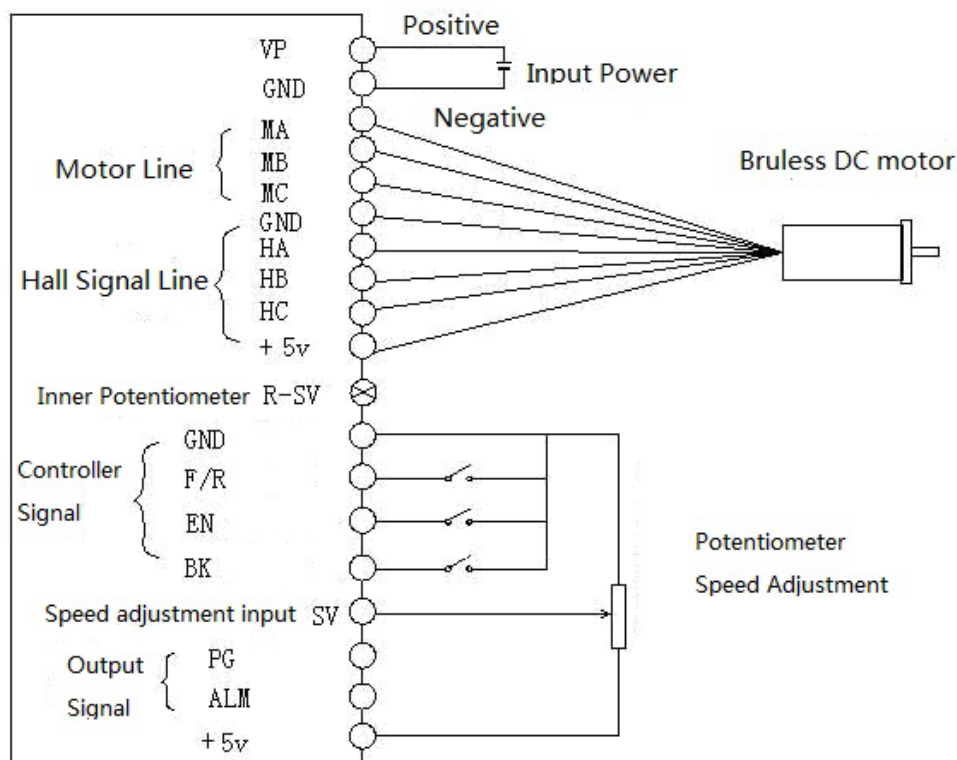

5. Dimension : 150×97×48mm

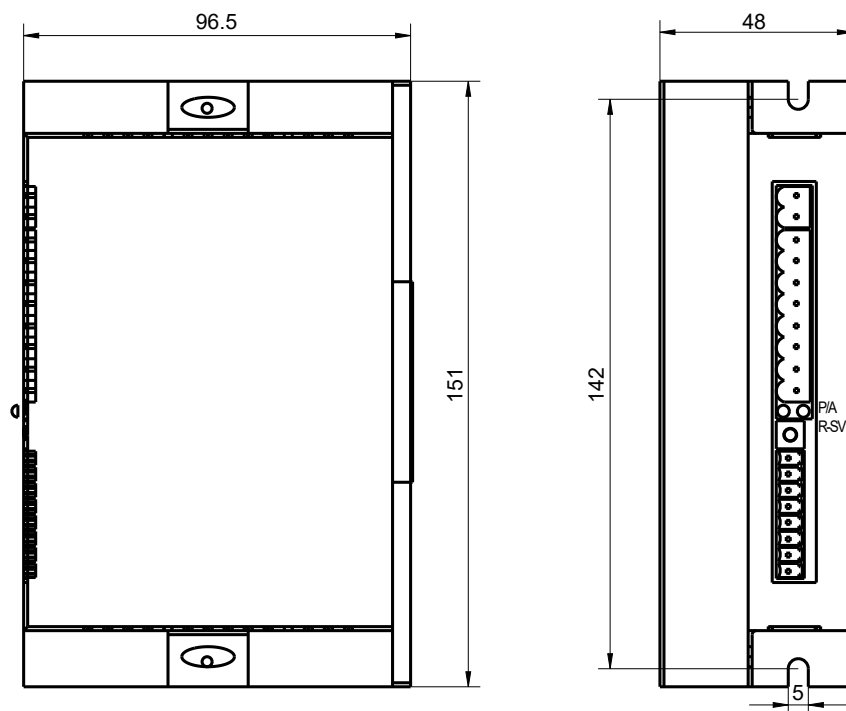

6. Functions and Usage

6.1 Speed Adjustment Method

This drive provide below two adjust methods for the user to choose:

Inner potentiometer speed adjustment : rotate the potentiometer on the driver panel counterclockwise, the rotate speed of the motor will decrease, rotate the potentiometer on the driver panel clockwise, The rotate speed become higher. If you use external input to adjust speed, make sure the potentiometer is set in the min. state.

External speed adjustment : Connect on the GND and +5V of the drives, speed can be adjusted on external potentiometer ((5K~100K) when connect SV terminal. Input simulate voltage through other control command (e.x. PLC, SCM etc.) to SV terminal to achieve the speed adjust as well (relative GND). The range of the SV terminal is DC 0V~+5V, the relevant motor speed is 0~rated speed.

External digital signal speed regulation : Add 5V between SV and GND, speed can be adjusted by PWM control between the 1KHz~2KHz, motor speed is influenced by duty. At this time, by adjusting the R-SV potentiometer, SV digital signal amplitude can be 0~1.0 ratio

attenuation processing. Generally, adjust R-SV to 1.0, SV input digital signal without attenuation processing.

6.2 Motor Operate / Stop Control (EN)

You can control the brushless motor to run or stop by controlling the terminal “EN” and “GND” connecting. The motor will running when we connect the terminal “EN” to “GND”; when shut down, the motor will stop naturally, and the stopping time will decided by the motor inertia and load add on the motor.

6.3 Motor Rotation Direction Control (F/R)

You can control the motor rotation direction by controlling the terminal “F/R” and “GND” connection. When connect terminal “F/R” to terminal “GND”, the motor will run at CCW (view from motor output side), and when shut down, the motor will run at another direction.



Attention

If you need to change the motor rotation direction, please stop the motor at first, otherwise the driver shall be damaged.

6.4 Brake the Motor to Stop (BK)

You can break the motor to stop if need. The motor will run when the terminal “BK” not connects to “GND”, but if you connect these two terminals, the motor will stop quickly. And the motor stopping time will be decided by inertia and load adding on the motor.



Attention

If you are not necessary to stop the motor quickly, please don't use with this function since it has some electrical and mechanical impact on the motor and controller.

6.5 Speed Signal Output (PG)

The speed pulse output is 0C, output 30V/10mA max. You can connect with a resistance (3K ohm ~10K ohm) between the signal and the input power to get the speed pulse signal. 3xN Output Pulse per revolution, N is pole of motor, Example: 2 pairs of pole motor, 12 pulses per revolution, when the motor speed is 500 rev/min, the pulses from PG output pulses are 6000.

6.6 Alarm Output (ALM)

The alarm output port is 0C, output 30V/10mA max. You can connect with a resistance (3K ohm ~10K ohm) between the signal and the input power to get the alarm signal. When

alarm, this port and the GND connecting (Low voltage), and the controller will stop working and keep in alarm status.

6.7 Drive Failure

Over voltage or over current can lead the driver to a protected status, the drive will automatically stop working, the motor stop and blue light is flashing. As long as you enable terminal re-reset (EN and GND disconnected) or power Off, the driver will disarm the alarm. When this failure occurs, please check the motor wire connection.

7. Using



1. Insure that motor line, hall line and power line connect correct, Motor and driver will be damaged if lines connected wrong.
2. When using inner potentiometer speed adjust, connect “EN” with “GND” terminal, connect SV terminal with 5V terminal, adjust speed by inner potentiometer.
3. When using external potentiometer to adjust speed: adjust R-SV to 1.0 position, meanwhile connect EN to GND terminal, connect external potentiometer (middle connection) to SV terminal, the other two connect GND and +5V terminal.
4. Motor will running with highest speed under closed loop, adjust attenuation potentiometer to get speed commanded.

 +86-0519-8517 7825

 +86-0519-8517 7807

 Building 1#,355 Longjin Road, Changzhou
Economic Development Zone, Jiangsu, China

 www.dingsmotion.com

International Customer

Person in Charge :

Daniel Jang

daniel@dingsmotion.com

Building 1#, 355 Longjin Road,
Changzhou Economic Development
Zone, Jiangsu, China

+86-519-85177826, 85177827

North America Customer

Person in Charge :

Nicolas Ha

sales@dingsmotionusa.com

335 Cochrane Circle Morgan Hill,
CA 95037

+1-408-612-4970

China Customer

Person in Charge :

Sweet Shi

info@dingsmotion.com

Building 1#, 355 Longjin Road,
Changzhou Economic Development
Zone, Jiangsu, China

+86-519-85177826, 85177827