



VER 1.0 **Technical Manual**

DS-OLS2-FPD Digital Stepping Driver



Table of Contents

 [Click to return to table of contents](#)

1.	Introduction.....	3
1.1	Features.....	3
1.2	Applications.....	3
2.	Specifications.....	4
2.1	Electrical Specifications.....	4
2.2	Environment.....	4
2.3	Mechanical Specifications.....	4
2.4	Elimination of Heat.....	5
3.	Connection Pin Assignments and LED Indication.....	6
3.1	P1 – Control Connector Configurations.....	6
3.2	P2 – Fault Output Connector.....	6
3.3	P3 – Power Connector.....	7
3.4	P4 – Motor Connector.....	7
3.5	Status LED Lights.....	7
4.	Control Signal and Fault Output.....	8
4.1	Control Signal Connection.....	8
4.2	Fault Output Connection.....	8
5.	Stepper Motor Connections.....	9
5.1	4-lead Motor Connection.....	9
5.2	6-lead Motor Connection	9
5.3	8-lead Motor Connection	10
6.	Power Supply Selection.....	11
6.1	Regulated or Unregulated Power Supply.....	11
6.2	Power Supply Sharing.....	11
6.3	Selecting Supply Voltage.....	11
7.	DIP Switch Configurations.....	12
7.1	Output Current Configuration (SW 1-3).....	12
7.2	Micro Step Configuration (SW 4-6).....	13
7.3	Pulse Mode Configuration (SW 7).....	13
7.4	Self-Test Configuration (SW 8).....	13
8.	Wiring Notes.....	14
9.	Typical Connection.....	15
10.	Sequence Chart of Control Signals.....	16
11.	Protection Functions.....	17
12.	Troubleshooting.....	18



1. Introduction

The DS-OLS2-FPD is a new digital stepper drive based on DINGS's widely implemented DM stepper drives (10+ millions of units in field). While retaining features of simple design, easy setup, high precision and reliability, DINGS' has also upgraded it by adopting the latest stepper control technology and added additional advanced features for better torque (10-25%), quicker response time, control command smoothing, easy self-test, etc.

The DS-OLS2-FPD is able to power 2 phase (1.8°) and 4 phase (0.9°) stepper motors smoothly with very low motor heating & noise. It can take 18-36VDC supply voltage and output 0.3 to 2.2A current. All the micro step and output current configurations can be easily done via built in DIP switches. Its control type (step & direction or CW/CCW) and command smooth filtering can also be configured via DIP switches. Therefore, the DS-OLS2-FPD is an ideal choice for many applications requiring simple step & direction or CW/CCW control of NEMA 8, 11, 14 and 17 stepper motors.

1.1 Features

- Step & direction (PUL/DIR) or CW/CCW (double pulse) control
- 18-36VDC supply voltage
- 200KHz max pulse input frequency
- 16 micro-step resolutions of 200-25,600 via DIP switches
- 8 output current settings of 0.3 – 2.2A via DIP Switches
- Configurable control command smoothing for performance excellence
- Automatic idle current reduction to 50% or 90%
- Convenient self-test for easy diagnosis
- Automatic self-configuration to match wide-range NEMA 8, 11, 14 and 17 stepper motors
- Anti-Resonance for optimal torque, extra smooth motion, low motor heating and noise
- Soft-start with no “jump” when powered on
- Optically isolated inputs
- Fault output
- Over-voltage and over-current protections
- CE certified and RoHS compliant

1.2 Applications

The DS-OLS2-FPD stepper drive is designed to power 2 phase (1.8°) or 4 -phase (0.9°) NEMA 8, 11, 14 and 17 hybrid stepper motors. It can be adopted in many industries (CNC machinery, electronics, medical, automation, packaging...) for applications such as 3D printer, automation machines, medical machines, laser cutters, X-Y tables, labeling machines, pick-place devices, etc. Its excellent performance, simple design, and easy setup features make DS-OLS2-FPD ideal for many step & direction control type applications.

2. Specifications

2.1 Electrical Specifications



Parameters	Min	Typical	Max	Unit
Output Current	0.3	-	2.2 (1.56 RMS)	A
Supply Voltage	18	24	36	VDC
Logic signal current	7	10	16	mA
Pulse input frequency	0	-	200	kHz
Minimal pulse width	2.5	-	-	μS
Minimal direction setup	5.0	-	-	μS
Isolation resistance	500	-	-	MΩ

2.2 Environment

Cooling	Natural Cooling or Forced cooling	
	Environment	Avoid dust, oil fog and corrosive gases
Operating Environment	Ambient Temperature	0 – 65°C (32 - 149°F)
	Humidity	40 – 90%RH
	Operating Temperature	0 – 50°C (32 - 122°F)
	Vibration	10-50Hz / 0.15mm
Storage Temperature	-20°C – 65°C (-4°F - 149°F)	
Weight	Approx. 150g (5.3 oz)	

2.3 Mechanical Specifications

(unit: mm [1inch=25.4mm])

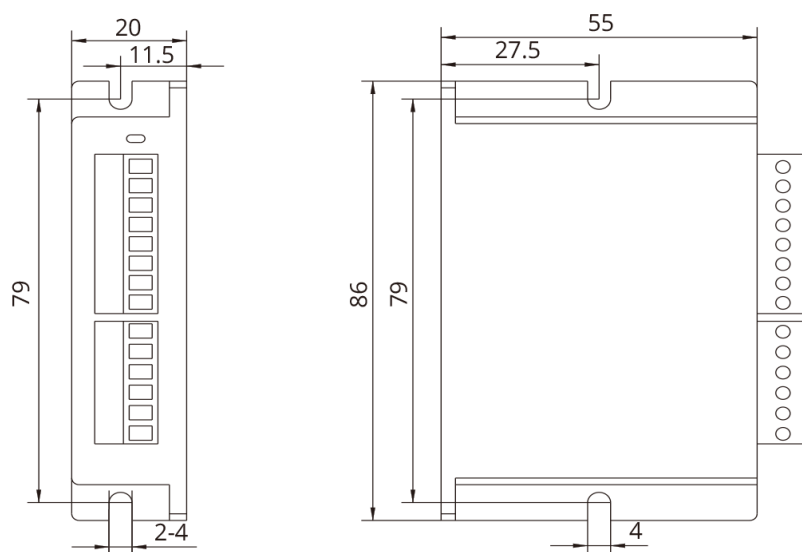

SW6 SW7 SW8 SW5 SW4 SW3 SW2 SW1							RS232	PWR/ALM
DINGS 鼎智							PUL+	
www.dingsmotion.com							PUL-	
DS-OLS2-FPD							DIR+	
							DIR-	
Current Table			Pulse/rev Table				ENA+	
Peak	SW1	SW2	SW3	Mstep	SW4	SW5	SW6	ENA-
0.3A	on	on	on	200	on	on	on	ALM+
0.5A	off	on	on	400	off	on	on	ALM-
0.7A	on	off	on	800	on	off	on	GND
1.0A	off	off	on	1600	off	off	on	+Vdc
1.3A	on	on	off	3200	on	on	off	A+
1.6A	off	on	off	6400	off	on	off	A-
1.9A	on	off	off	12800	on	off	off	B+
2.2A	off	off	off	25600	off	off	off	B-
ALM LED Codes		SW7: Pulse Mode						
ALM	RD Times	off=PUL/DIR, on=CW/CCW						
Over current	1	SW8: Self Test						
Over voltage	2	off=Disable, on=Enable						
VDC: +18V~+36V Control Signal: 5V								

Figure 1 Mechanical specifications

* Side mounting recommended for better heat dissipation

2.4 Elimination of Heat



- DS-OLS2-FPD's working temperature is less than 60°C (140°F)
- It is recommended to use automatic idle-current mode to reduce motor heating. That means set the SW4 pin of DIP switch at "OFF" position.
- It is recommended to mount the drive vertically to maximize heat sink area. Use forced cooling method to cool if necessary.

3. Connection Pin Assignments and LED Indication

3.1 P1 – Control Connector Configurations



PIN	Details
PUL+	<p>Pulse Connection: Required.</p> <ul style="list-style-type: none"> (1) 5-24V, optically isolated, differential. (2) Maximum 200KHz input frequency. (3) Pulse width of 2.5µs or longer. (4) In single pulse (step & direction) control mode, this input signal represents a pulse which is active at the rising or falling voltage edge (set by DIP switch SW13); in double pulse (CW/CCW) control mode, this input signal represents clockwise (CW) pulse which is active at both high voltage level and low voltage level.
PUL-	
DIR+	<p>Direction Connection: Required.</p> <ul style="list-style-type: none"> (1) 5-24V, optically isolated, differential. (2) Maximum 200KHz input frequency. (3) Pulse width of 2.5µs or longer. (4) Minimal DIR signal setup time should be at least 5µs. (5) In single pulse (step & direction) control mode, this signal represents controls motion rotation direction; in double pulse (CW/CCW) control mode, this input signal controls counterclockwise (CCW) rotation direction and is active at both voltage high level and low level.
DIR-	
ENA+	<p>Enable Connection: Optional.</p> <ul style="list-style-type: none"> (1) Optically isolated, differential. (2) Disable the drive by 5-24V input connection; enable the drive by 0-0.5 VDC connection. (3) This connection is optional (defaulted to unconnected) with drive enabled. (4) By default, motor shaft is unlocked when drive disabled but can be configured to shaft locked by DIP switch SW15.
ENA-	

Notes to avoid interference: (1) shield control signal wires; (2) don't tie PUL/DIR control signal cable and motor wires together

3.2 P2 – Fault Output Connector

Pin	Details
ALM+	<p>Fault Output Connection: Optional. (1) Maximum 24V/80mA output when over-voltage and over-current error protections activated. (2) Sinking or sourcing. (3) The resistance between ALM+ and ALM- is low impedance as default (configurable by DIP switch SW12), and will change to high when the drive goes into error protection.</p>
ALM-	

3.3 P3 – Power Connector



Pin	Details
GND	Connect to power supply ground connection.
+VDC	Connect to power supply positive connection. Suggest 18-36VDC power supply voltage

	Warning	Don't plug/unplug P3 or any P1/P2/P4 terminal block to avoid drive damage or injury while powered on.
--	----------------	--

3.4 P4 – Motor Connector

PIN	Details
A+	Connect to motor A+ wire
A-	Connect to motor A- wire
B+	Connect to motor B+ wire
B-	Connect to motor B- wire

3.5 Status LED Lights

There are two LED lights for DS-OLS2-FPD. The GREEN one is the power indicator which should be always on in normal circumstance. The RED one is a drive status indication light, which will be OFF while working normally but ON and flash 1-2 times in a 3-second period in the case of enabled over-voltage or over-current protection.

4. Control Signal and Fault Output

4.1 Control Signal Connection



The DS-OLS2-FPD can accept differential or single-ended control signals (pulse, direction, and enable) in open-collector or PNP connection through the P1 connector (figure 2). It is recommend to add an EMI line filter between the power supply and the drive to increase noise immunity for the drive in interference environments.

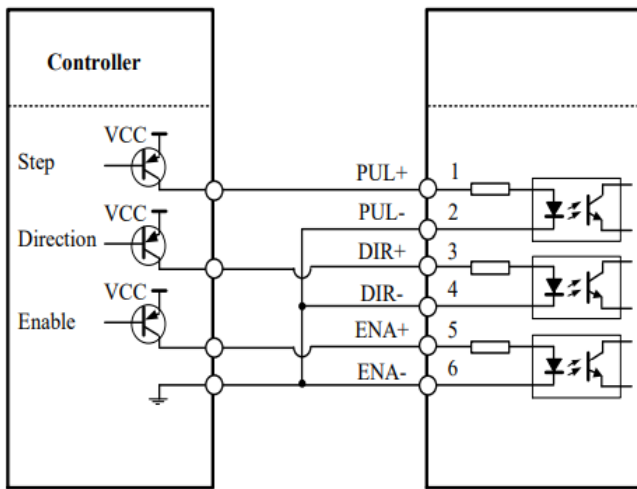

Figure 3 Connections to open-collector signals
(Common-anode)

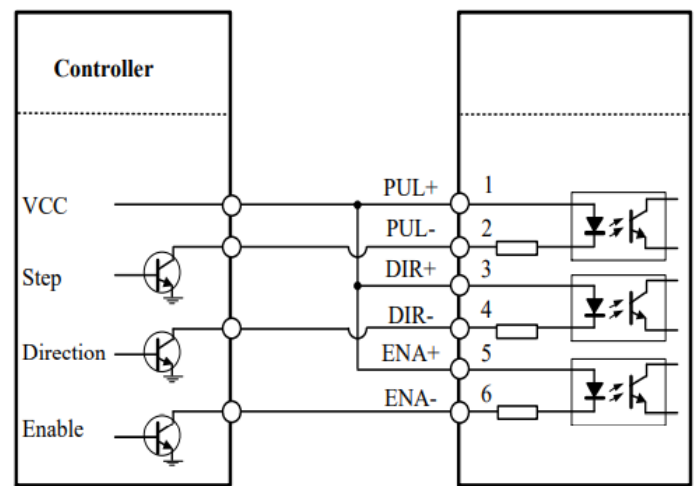

Figure 4 Connections to PNP signals
(Common-cathode)

4.2 Fault Output Connection

When over voltage or over current protection happens, DS-OLS2-FPD red status LED light will blink and the impedance state between ALM+ and ALM- will change (from low to high or high to low depending on configuration) and can thus be detected. Fault output connection is optional, and it can be connected either in sinking or sourcing.

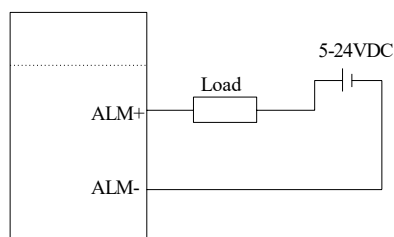

Figure 5 Sinking output

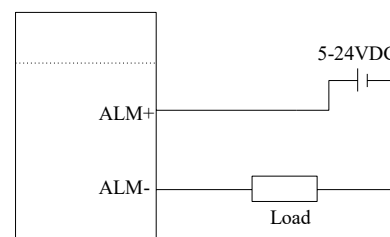

Figure 6 Sourcing output



5. Stepper Motor Connections

DS-OLS2-FPD can drive 2-phase and 4-phase bipolar hybrid stepper motors with 4, 6, or 8 wires. Although setting the output current to 1.4 times of motor phase current will get maximum torque from the motor, at the same time motor heating will be also maximized. So, just configure the drive output current to a value which will get sufficient torque to reduce motor heating.

5.1 4-lead Motor Connection

Refer to figure 7 for how to connect a 4-wire stepper motor. Configure DS-OLS2-FPD output current to one of the 8 available values through DIP switches SW 1-3 of the DIP switch selector 1 (figure 2).

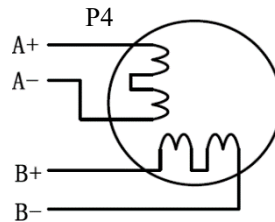

Figure 7 4-lead Motor Connection

5.2 6-lead Motor Connection

DS-OLS2-FPD can power 6-lead stepper motors through half coil connection (half chopper) or full coil (full copper) connection. The half coil connection only uses one half of the motor's windings and is usually selected in applications requiring high speed but lower torque. The full coil connection uses the full coil windings and is usually selected in high-torque required applications. Refer to figure 7 and 8 for those two connections.

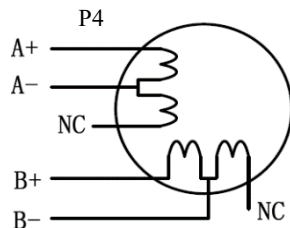

Figure 8 6-lead motor half coil connection

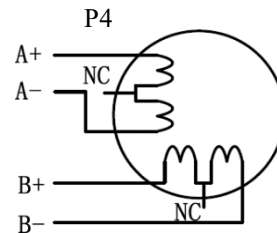

Figure 9 6-lead motor full coil connection

5.3 8-lead Motor Connection



DS-OLS2-FPD can power 8-lead in series or parallel connection in series or parallel.

5.3.1 Series Connection

Series connected 8-lead stepper motors are typically implemented in applications which higher torque at lower speed movement is required. Because a stepper motors under series connection has the most inductance, the performance will start to degrade when the motor runs at higher speed. For this connection, it is suggested to set an DS-OLS2-FPDs output RMA current to no more than 70% of the stepper motor's phase current to prevent overheating. See the next figure for how to connect an 8-lead stepper motor for series connection.

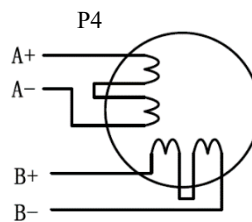

Figure 10 8-lead motor series connection

5.3.2 Parallel Connection

Parallel connected 8-lead stepper motors are typically implemented in applications which higher torque at high speed movement is required. Compared with series connection, a parallel connected stepper motor has lower inductance and therefore have better torque performance at higher speed movement. Although setting the drive output current to 1.4 times of driven motor phase current will get the most torque, it is suggested to set an DS-OLS2-FPDs output current (peak of sinusoidal) to no more than 1.2 times the stepper motors phase current to prevent overheating. Refer to the next figure for how to connect an 8-lead stepper motor for parallel connection.

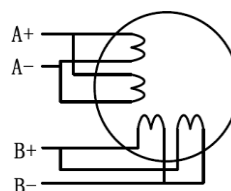

Figure 11 8-lead motor parallel connection



6. Power Supply Selection

DS-OLS2-FPD is designed to power small and medium size stepping motors (frame sizes NEMA 8 to 17) made by DINGS or other motor manufacturers. To get optimal performances, it is important to select proper power supply type, voltage, and supply output current. In general power supply voltage determines the high speed performance of a stepper motor, while drive output current determines the driven motor torque output. Higher supply voltage can increase motor speed torque performance, but at the same time result in more noise and motor heating. For low motor speed applications, it is suggested to use lower supply voltage power supplies.

6.1 Regulated or Unregulated Power Supply

Both regulated and unregulated power supplies can be used to power an DS-OLS2-FPD. Theoretically unregulated power supplies are preferred due to their ability to withstand back EMF current surge and faster response for current change. If you prefer to use a regulated power supply instead, it is suggested to choose one specially designed for stepper or servo controls such as one DINGS' RPS series power supply. In the case when only general purpose switching power supplies are available, choose one with "OVERSIZED" current output rating (for example, using a 4A power supply for 3A stepper motor) to avoid current clamp. On the other hand, if unregulated supply is used, one may use a power supply of lower current rating than that of motor (typically 50% ~ 70% of motor phase current). The reason is that the drive only draws current from an unregulated power supply during the ON duration of the PWM cycle, but not during the OFF duration.

6.2 Power Supply Sharing

Multiple DS-OLS2-FPD drives can share the same power supply, if that power supply has enough capacity. To avoid cross interference, connect each DS-OLS2-FPD DIRECTLY to that shared power supply separately instead of connecting those power connectors of drives in daisy-chain connection.

6.3 Selecting Supply Voltage

DS-OLS2-FPDs operating voltage is 18–36 VDC. Because of voltage increasing from potential power line voltage fluctuation and back EMF voltage generated during motor deceleration, it is suggested to use a 24 VDC power supply.

7. DIP Switch Configurations



Each DS-OLS2-FPD has two 2-bit DIP switch selectors. The first one is located on the side (DIP switch selector 1 in Figure 2) and used to configure settings of micro step resolution, output current, and motor standstill current as shown below:

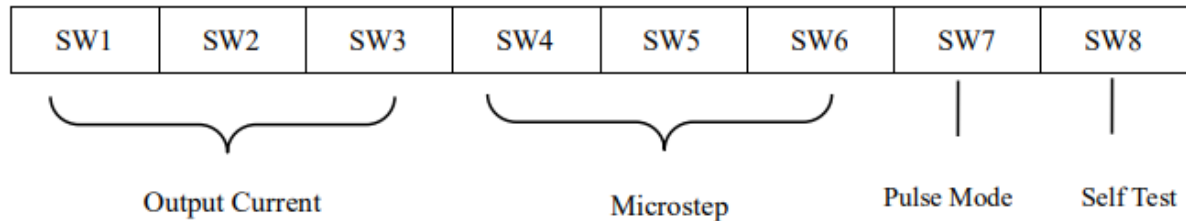

7.1 Output Current Configuration (SW 1-3)

The DS-OLS2-FPD has 8 micro step settings which can be configured through DIP switch SW1, SW2 and SW3.

For a given stepper motor, higher drive output current will make it output higher torque, but at the same time cause more heating for both the motor and drive. Therefore, output current is generally set to be such that the motor will not overheat for long time operation. Since parallel and serial connections of motor coils will significantly change resulting inductance and resistance, it is therefore important to set drive output current depending on motor phase current, motor leads and connection methods. Phase current rating supplied by motor manufacturer is important in selecting drive current; however the selection also depends on leads and connections.

The first three bits (SW1, 2, 3) of the DIP switch are used to set the dynamic current. Select a setting closest to your motor's required current.

Peak Current	RMS Current	SW1	SW2	SW3
0.3A	0.21A	ON	ON	ON
0.5A	0.35A	OFF	ON	ON
0.7A	0.49A	ON	OFF	ON
1.0A	0.71A	OFF	OFF	ON
1.3A	0.92A	ON	ON	OFF
1.6A	1.13A	OFF	ON	OFF
1.9A	1.34A	ON	OFF	OFF
2.2A	1.56A (default)	OFF	OFF	OFF

7.2 Micro Step Configuration (SW 4-6)



Each DS-OLS2-FPD has 8 micro step settings which can be configured through DIP switch SW4, SW5, SW6. See the following table for detail.

Micro step	Pulses/Rev. (for 1.8°motor)	SW4	SW5	SW6
1	200	ON	ON	ON
2	400	OFF	ON	ON
4	800	ON	OFF	ON
8	1600 (default)	OFF	OFF	ON
16	3200	ON	ON	OFF
32	6400	OFF	ON	OFF
64	12800	ON	OFF	OFF
128	25600	OFF	OFF	OFF

7.3 Pulse Mode Configuration (SW 7)

DIP switch SW7 is used to configure the control mode of DS-OLS2-FPD. By default it is set to OFF position for single pulse (step & direction, or pulse & direction) control. To change the control model to double pulse (CW/CCW) control type, set its position to OFF.

7.4 Self – Test Configuration (SW 8)

For test and system diagnosis purpose, EM442 is featured with Self-Test. Anytime DIP switch SW8 is switched to ON position, the drive will automatically rotate the driven stepper motor back and forth for one round in each direction. Set this switch position to OFF for normal operation.



8. Wiring Notes

- In order to improve anti-interference performance of the drive, it is recommended to use Twisted pair shield cable.
- To prevent noise incurred in PUL/DIR signal, pulse/direction signal wires and motor wires should not be tied up together. It is better to separate them by at least 10 cm; otherwise the disturbing signals generated by motor will easily disturb pulse direction signals, causing motor position error, system instability and other failures.
- If only one power supply serves multiple DS-OLS2-FPD drives, separately connecting the drives to the power supply is recommended instead of daisy-chaining.
- It is prohibited to pull and plug connector P4 while the drive is powered ON, because there is high current flowing through motor coils (even when motor is at standstill). Pulling or plugging connector P4 with power on will cause extremely high back-EMF voltage surge, which may damage the drive.



9. Typical Connection

A complete stepping system should include stepping motor, stepping drive, power supply and controller (pulse generator). A typical connection is shown as figure 11.

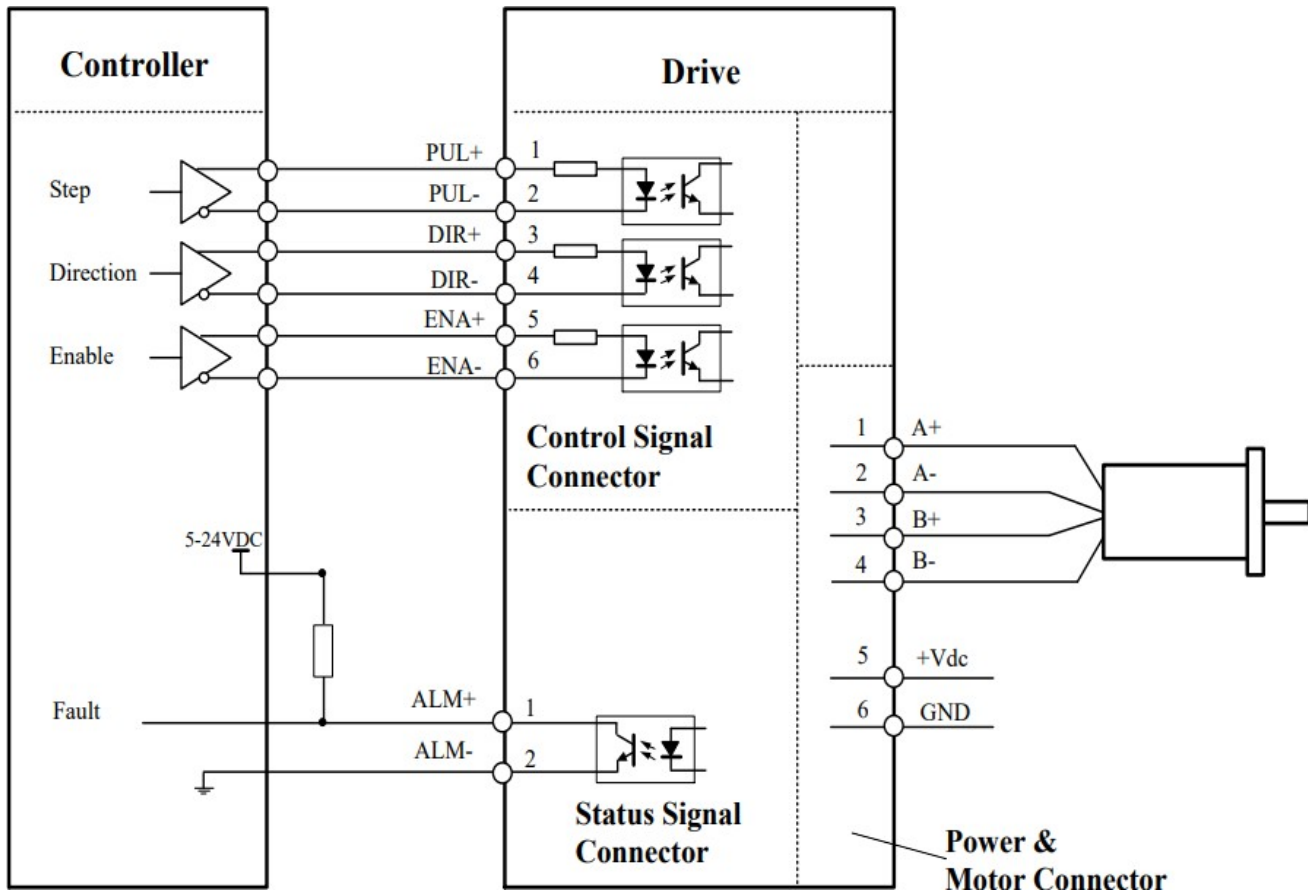

Figure 12 Typical connection



10. Sequence Chart of Control Signals

In order to avoid some fault operations and deviations, PUL, DIR and ENA should abide by some rules, shown as following diagram:

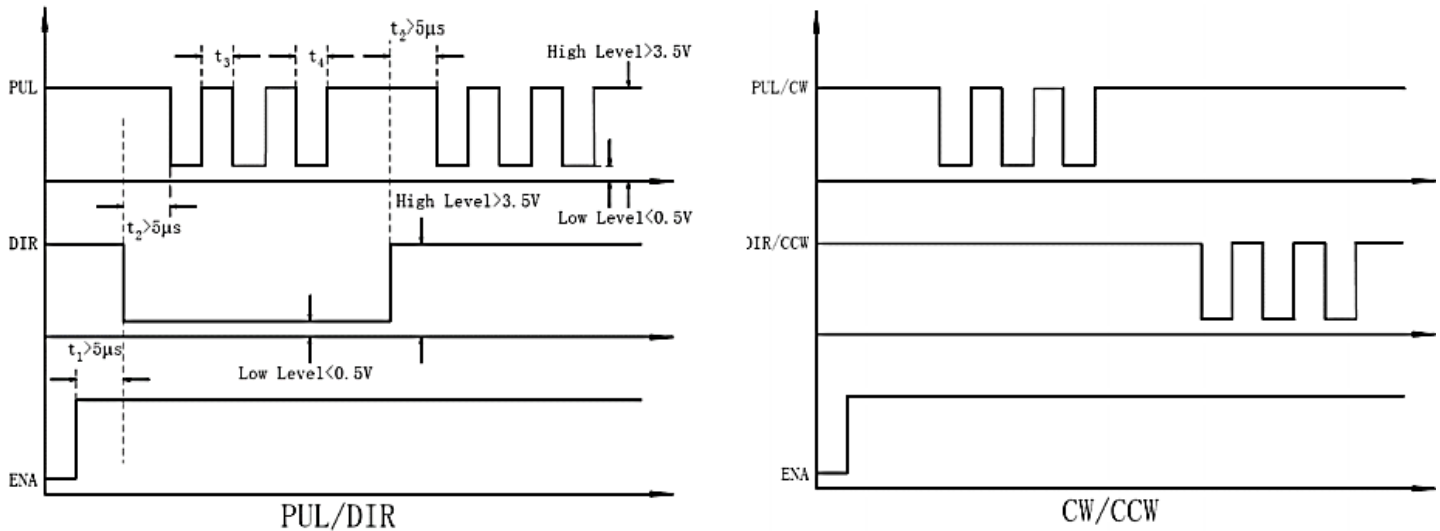

Figure 13 Sequence chart of control signals

Remark :

- a) t_1 : ENA must be ahead of DIR by at least $5\mu\text{s}$. Usually, ENA+ and ENA- are NC (not connected). See "Connector P1 Configurations" for more information.
- b) t_2 : DIR must be ahead of PUL effective edge by $5\mu\text{s}$ to ensure correct direction;
- c) t_3 : Pulse width not less than $2.5\mu\text{s}$;
- d) t_4 : Low level width not less than $2.5\mu\text{s}$.



11. Protection Functions

DS-OLS2-FPD incorporates are built with over-voltage and over-current error protections. When it is under error protection, the red LED light will blink for one or two times in a period of 3 seconds. If fault output connection is connected, the impedance mode between ALM+ and ALM- will be changed (See “Fault Output Configuration” section for detail).



Priority	Time(s) of Blink	Sequence wave of red LED	Description
1 st	1		Over-current protection activated when peak current exceeds the limit.
2 nd	2		Over-voltage protection activated when drive working voltage is greater than 40VDC

Figure 14 Error Protections

When above protections are active, the motor shaft will be free or the red LED blinks. Reset the drive by repowering it to make it function properly after removing above problems.



12. Troubleshooting

In the event that your drive doesn't operate properly, the first step is to identify whether the problem is electrical or mechanical in nature. The next step is to isolate the system component that is causing the problem. As part of this process you may have to disconnect the individual components that make up your system and verify that they operate independently. It is important to document each step in the troubleshooting process. You may need this documentation to refer back to at a later date, and these details will greatly assist our Technical Support staff in determining the problem should you need assistance.

Many of the problems that affect motion control systems can be traced to electrical noise, controller software errors, or mistake in wiring.

Problem Symptoms and Possible Causes

Symptoms	Possible Problems
Motor is not rotating	No power
	Pulse/revolution setting is wrong
	DIP switch current setting is wrong
	Fault condition exists
Motor rotates in the wrong direction	The drive is disabled
	Motor phases may be connected in reverse
The drive in fault	DIP switch current setting is wrong
	Something wrong with motor coil
	Control signal is too weak
Erratic motor motion	Control signal is interfered
	Wrong motor connection
	Something wrong with motor coil
	Current setting is too small, losing steps
Motor stalls during acceleration	Current setting is too small
	Motor is undersized for the application
	Acceleration is set too high
	Power supply voltage too low
Excessive motor and drive heating	Inadequate heat sinking / cooling
	Automatic current reduction function not being utilized
	Current is set too high



+86-0519-8517 7825



+86-0519-8517 7807



Building 1#,355 Longjin Road, Changzhou
Economic Development Zone, Jiangsu, China



www.dingsmotion.com

International Customer

Person in Charge :

Daniel Jang

daniel@dingsmotion.com

Building 1#, 355 Longjin Road,
Changzhou Economic Development
Zone, Jiangsu, China

+86-519-85177826, 85177827

North America Customer

Person in Charge :

Nicolas Ha

sales@dingsmotionusa.com

335 Cochrane Circle Morgan Hill,
CA 95037

+1-408-612-4970

China Customer

Person in Charge :

Sweet Shi

info@dingsmotion.com

Building 1#, 355 Longjin Road,
Changzhou Economic Development
Zone, Jiangsu, China

+86-519-85177826, 85177827