

| REVISION | | | |
|----------|------|-------------|----------|
| REV. | DATE | DESCRIPTION | DRAWN BY |
| | | | |

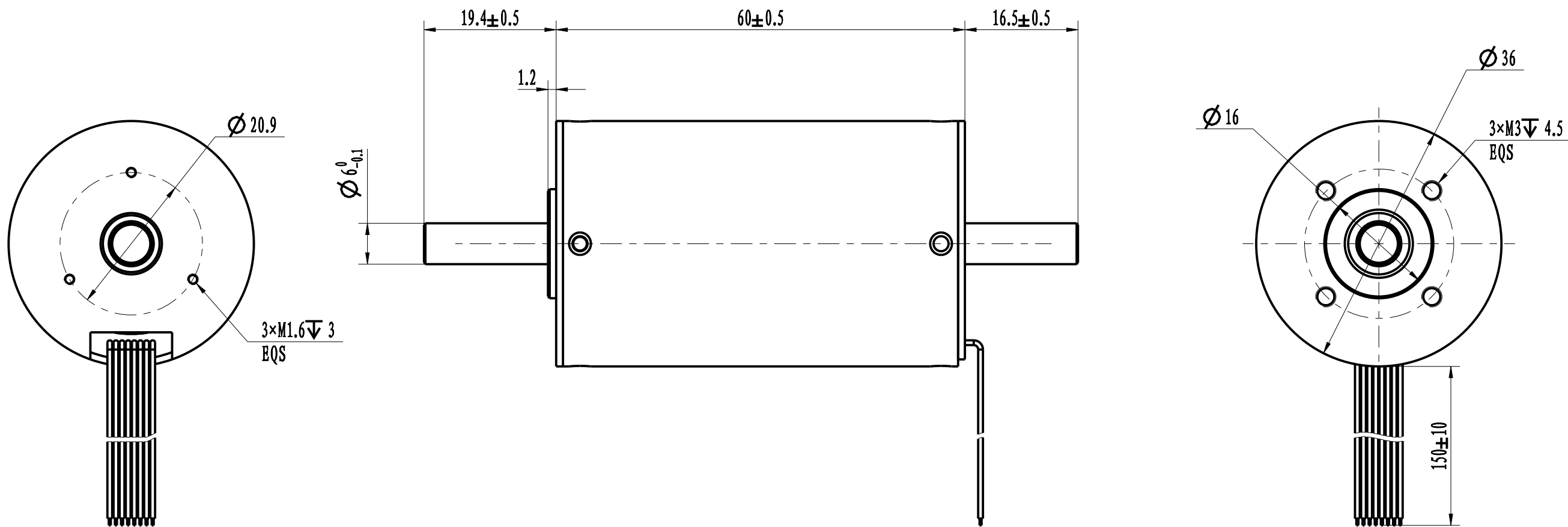

| | | | |
|---------------------------|------|-----------------------------------|-----------------------|
| REDUCTION RATIO | / | DIELECTRICAL STRENGTH | AC500V,1mA,1s |
| POLE RAIRS | 1 | INSULATION RESISTANCE | 100M Ω /DC500V |
| RATED VOLTAGE(VDC) | 24 | DUTY TYPE | S1 |
| RATED CURRENT(A) | 4.1 | PROTECTION GRADE | / |
| RATED SPEED(RPM) | 9300 | INSULATION CLASS | F |
| RATED TORQUE(mN·m) | 70 | COOLING TYPE | / |
| RATED POWER(W) | 69 | TORQUE CONSTANT(mN·m/A) | 17.07 |
| BACK EMF CONSTANT(V/KRPM) | 1.79 | ROTOR INERTIA(g·cm ²) | 39 |

CUSTOMER

WIRING CHART

NOTICE TO PERSONS RECEIVING THIS DRAWING
 THIS DRAWING IS ONLY CONDITIONALLY ISSUED, AND FOR THE SOLE PURPOSE OF INFORMING LICENSEES AND ASSOCIATE CONTRACTORS OF DINGS' MOTION, AND VENDORS THERETO AND CUSTOMERS THEREOF, RECEIPT OR POCESSION THEREOF DOES NOT CONFER TO TRANSFER ANY RIGHT IN THE SUBJECT MATTER OF THE DRAWING. THE DESIGN, CONSTRUCTION, TECHNICAL INFORMATION AND ALL OTHER SUBJECT MATTER SHOWNIN THIS DRAWING ARE AND REMAIN, EXCEPT AS MAY BE OTHERWISE INDICATED BY WRITTEN NOTICE HEREON, THE EXCLUSIVE PROPERTY OF SAID CORPORATION. THIS DRAWING MAY BE REPRODUCED ONLY BY LICENSEES AND ASSOCIATE CONTRACTORS OF SAID CORPORATION AND ONLY FOR LICENSED MANUFACTURE, AND BY VENDORS MANUFACTURING FOR SAID CORPORATION AND ONLY FOR LICENSEES AND ASSOCIATECONTRACTORS.

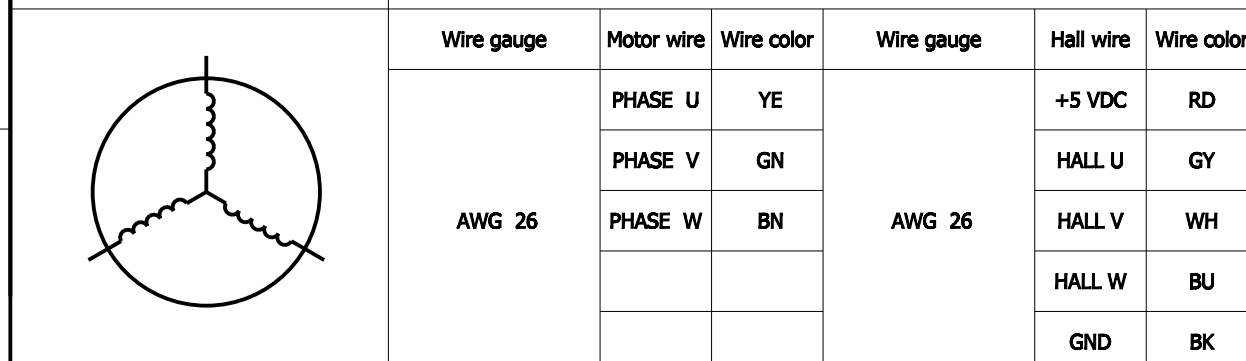

| Line color line sequence | | | | | | UNLESS OTHERWISE SPECIFIED ALL DIMENSIONS ARE IN MILLIMETERS AND TOLERANCES ARE AS BELOW | | DRAWN | DATE | |
|--------------------------|------------|------------|------------|-----------|------------|--|-----------|---------|-----------------|------|
| Wire gauge | Motor wire | Wire color | Wire gauge | Hall wire | Wire color | | | CHECK | DATE | |
| AWG 26 | PHASE U | YE | AWG 26 | +5 VDC | RD | LINERA | | APPRVD | DATE | |
| | PHASE V | GN | | HALL U | GY | 0~3 | ± 0.2 | 0~10 | $\pm 1.5^\circ$ | DATE |
| | PHASE W | BN | | HALL V | WH | 3~6 | ± 0.5 | 10~50 | $\pm 1^\circ$ | DATE |
| | | | | HALL W | BU | 6~30 | ± 0.8 | 50~120 | $\pm 30'$ | |
| | | | | GND | BK | 30~120 | ± 1.5 | 120~400 | $\pm 15'$ | |

DINGS

| | | | |
|-------|-----|-------|-----|
| SIZE | A3 | SHEET | 1/1 |
| SCALE | 2:1 | REV | A |

